

**X829 Asbestos  
Series  
15 & 20  
Gallon**

**Model: C82915-06  
C82920-06  
C82915-08  
C82920-08**

**OPERATION**

**SERVICE**

**PARTS**

**CARE**

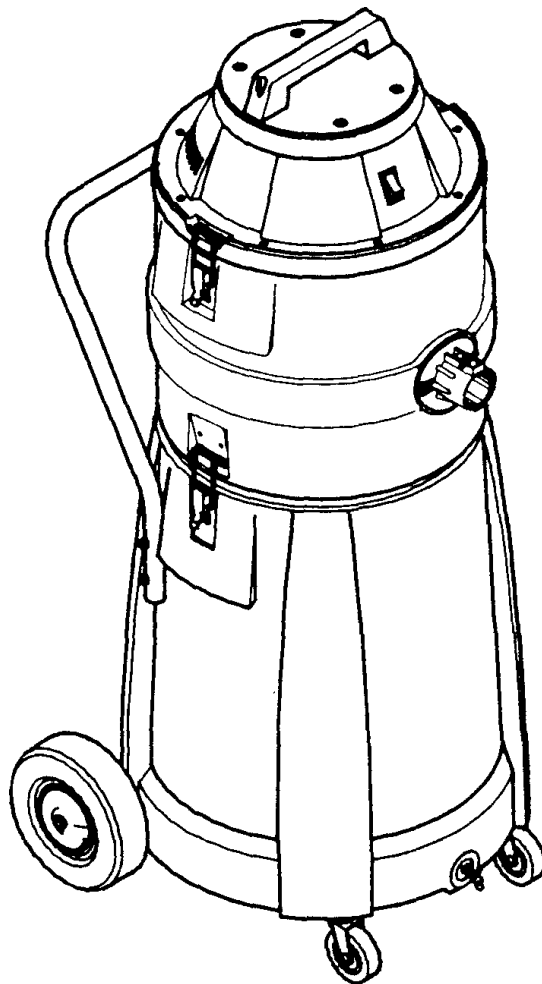

Revised 11/05

***Minuteman***<sup>®</sup>

# FOR COMMERCIAL USE ONLY

## IMPORTANT SAFETY INSTRUCTIONS

When using an electrical appliance, basic precautions should always be followed, including the following:

### READ ALL INSTRUCTIONS BEFORE USING

**WARNING** - To reduce the risk of fire, electric shock, or injury:

Do not leave appliance when plugged in. Unplug from outlet when not in use and before servicing.

### WARNING

To reduce the risk of electric shock - Do not expose to rain. Store indoors.

- Do not allow to be used as a toy. Close attention is necessary when used by or near children.
- Use only as described in this manual. Use only manufacturer's recommended attachments.
- Do not use with damaged cord or plug. If appliance is not working as it should, has been dropped, damaged, left outdoors, or dropped into water, return it to a service center.
- Do not pull or carry by cord, use cord as a handle, close a door on cord, or pull cord around sharp edges or corners. Do not run appliance over cord. Keep cord away from heated surfaces.
- Do not unplug by pulling on cord. To unplug, grasp the plug, not the cord.
- Do not handle plug or appliance with wet hands.
- Do not put any object into openings. Do not use with any opening blocked; keep free of dust, lint, hair, and anything that may reduce air flow.
- Keep hair, loose clothing, fingers, and all parts of body away from openings and moving parts.
- Do not pick up anything that is burning or smoking, such as cigarettes, matches, or hot ashes.
- Do not use without dust bag and/or filters in place.
- Turn off all controls before unplugging.
- Use extra care when cleaning on stairs.
- Do not use to pick up flammable or combustible liquids such as gasoline or use in areas they may be present.
- Connect to a properly grounded outlet only. See grounding instructions.

### SAVE THESE INSTRUCTIONS

# INSPECTION

Carefully unpack and inspect your machine for shipping damage. Each unit is tested and thoroughly inspected before shipment, and any damage is the responsibility of the delivery carrier who should be notified immediately.

## ELECTRICAL - 115 Volt

This machine is designed to operate on a standard 15 amp. 115 volt, 60 hz, AC circuit. Voltages below 105 volts AC or above 125 volts AC could cause serious damage to the motor.

## ELECTRICAL - 240 Volt

This machine is designed to operate on a standard 16 amp. type L fused 230 volt, 50 hz, AC circuit. Voltages below 200 volts AC or above 250 volts AC could cause serious damage to the motor. I.E.C. Class I.

# WARNING

Electric motors can cause explosions when operated near explosive materials or vapors. Do not operate this machine near flammable materials such as solvents, thinners, fuels, grain dust, etc.

# GROUNDING INSTRUCTIONS

This appliance must be grounded. If it should malfunction or breakdown, grounding provides a path of least resistance for electric current to reduce the risk of electric shock. This appliance is equipped with a cord having an equipment-grounding conductor and grounding plug. The plug must be plugged into an appropriate outlet that is properly installed and grounded in accordance with all local codes and ordinances.

**DANGER** - Improper connection of the equipment-grounding conductor can result in a risk of electric shock. Check with a qualified electrician or service person if you are in doubt as to whether the outlet is properly grounded. Do not modify the plug provided with the appliance — if it will not fit the outlet, have a proper outlet installed by a qualified electrician.

This appliance is for use on a nominal 120-volt circuit and has a grounding plug that looks like the plug illustrated in sketch A below. Make sure that the appliance is connected to an outlet having the same configuration as the plug. No adapter should be used with this appliance.

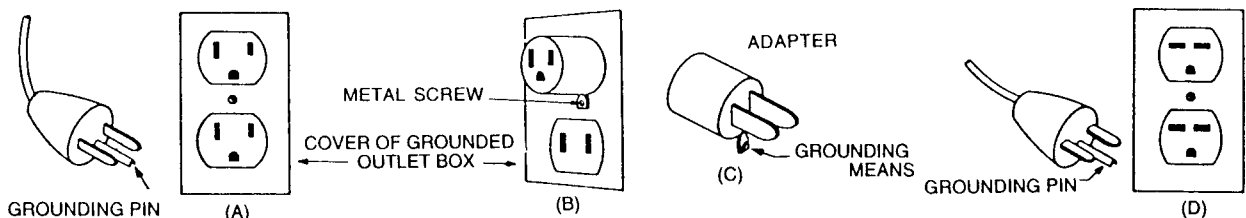

## **WARNING**

This vacuum may contain potentially hazardous dust depending on its application. Special handling of contaminated disposable bags and filters is recommended. Disposal must be in compliance with local EPA regulations.

## **USER MAINTENANCE INSTRUCTIONS**

All service and repair should be performed by qualified vacuum service representative or electrician. No user serviceable components are employed in the electrical vacuum lid head assembly. No lubrication of the motor is required.

## **CLOTH BAG & HOSE ASSEMBLY**

Cloth bag and hose assembly are user maintenance items and can be replaced when worn out. For optimum performance, empty and clean filter bag regularly. A clogged and dirty bag restricts the flow of air and results in reduced vacuum. The hose assembly can be maintained by wiping off with a dampened cloth of mild liquid soap and water, then allowed to dry.

## **CORD STORAGE**

While not in use storage can be accomplished by winding cord around motor lid assembly. Cord should be completely unwound from lid assembly during operation.

- Do not use with damaged cord or plug. If appliance is not working as it should, has been dropped, damaged, left outdoors, or dropped into water, return to service center.
- Do not pull or carry by cord, use cord as handle, close a door on cord, or pull cord around sharp edges or corners. Do not run appliance over cord. Keep cord away from heated surfaces.
- Do not unplug by pulling cord. To unplug, grasp the plug, not the cord.
- Do not handle plug or appliance with wet hands.

Always unplug the machine when removing the motor head off the tank. This equipment should be stored indoors and not exposed to rain.

## **TANK/FILTER SET-UP PROCEDURE**

Refer to Page 6

1. When using the poly adapter for dry pick-up follow the described procedures below for poly 6 mil. bag installation.
  - A. Insert poly bag into tank assembly draping all excess bag height over the edge of tank. Fully open bag inside tank to ensure that the bag is not bunched up and fully extended to the bottom of tank.
  - B. Depending on the weight of the dry material being recovered, it may be necessary to slit the poly bag 2" horizontally approximately 2" down from the top of the tank. This will stop the poly bag from closing in on the bottom on the poly adapter. After filling the bag tie off bag below slit and remove from tank.
2. Install poly 1:1 adapter (4) on top of tank assy. (6) as shown and snap tank latches.
3. Install filter protector (3) over cloth filter (2) and place in poly 1:1 adapter (4).
4. Position vacuum motor lid assy. (1) on top of poly 1:1 adapter and snap lid latches in place.
5. For proper cleaning of tank and removal/changing of filters, see procedure for removing contaminated filters and for cleaning of contaminated tank. (Page 5)

### **PROCEDURE FOR REMOVING CONTAMINATED FILTERS AND FOR CLEANING CONTAMINATED TANK**

For the benefit of your health, you should always wear a face mask approved for use with asbestos any time you are using or cleaning this vacuum cleaner. You should also wear gloves.

1. Unplug machine from power source.
2. Carefully and slowly remove lid only (be sure you have not accidentally lifted the cloth filter bag at the same time). Set the lid/filter assembly aside.
3. Gently tap the inside of the cloth bag to loosen any particles that may be on the opposite surface. Do this all around the inside surface of the bag.
4. Gently remove the cloth bag and set aside.
5. Remove filter protector from poly 1:1 and place in plastic bag marked "Hazardous Materials."
6. Using a wiping cloth, dampened with water (not soaking wet), wipe down all of the exposed surfaces inside of the 1:1 poly; put the cloth aside - do not discard.
7. Remove poly 1:1 adapter and wipe down bottom side of poly adapter.
8. Tie off poly bag inside tank and remove. Wipe down inside of tank and dispose of cloth.

### **CHANGING THE PRE-FILTER SLEEVE**

Refer to Item No. 2, Page 7

The pre-filter sleeve should be changed, using all of the precautions previously mentioned.

The pre-filter should be changed when any of the following take place:

1. Anytime there is an indication of a filter tear during normal operation of the unit.

This tear could be in any of the filters used:

- a. paper dust containment bag
- b. paper bag protector
- c. cloth filter bag

These tears would show up during the tank clean-out procedure, or . . . .

2. Every other tank clean-out period. To change the pre-filter, do the following before you do Step #3 of the normal clean-out procedure.
  - a. Wipe down all of the exposed surfaces on the underside of the removed lid, using the dampened wiping cloth (see Step #6).

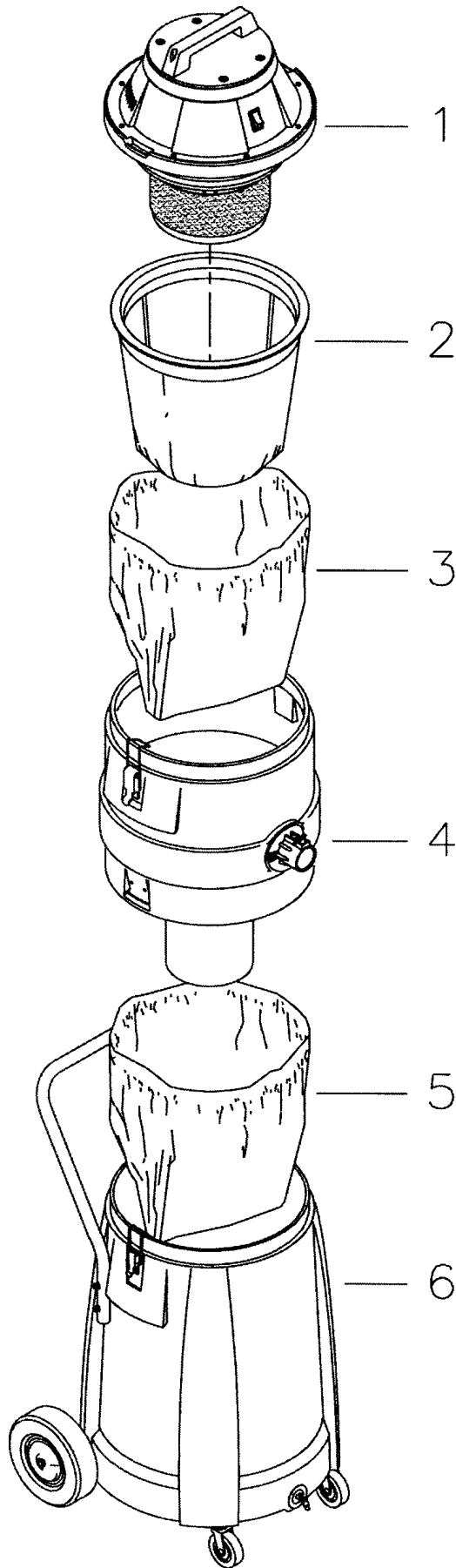

Poly Tank With 1:1 Adapter

1. Motor Lid Assembly
2. Cloth Filter with Frame
3. Filter Protector
4. 1:1 Poly Adaptor
5. Plastic Liner for Top Fill Dry Pickup
6. 15/20 Gallon Poly Tank

# WARNING INSTRUCTIONS FOR 800012 & 805037 PLASTIC BAGS

*TO PREVENT OVERHEATING AND DAMAGE TO THE MACHINE PLEASE FOLLOW THE INSTRUCTIONS BELOW!*

After placing the plastic recovery bag inside the tank, use a sharp knife to cut a 1" slit in the bag at the top edge of the tank, on the side opposite the vacuum intake. This will allow the vacuum pressure to equalize on both sides of the bag and prevent it from collapsing when the vacuum motor is turned on. Failure to follow this instruction may cause overheating or more serious damage and may void the warranty on this machine!

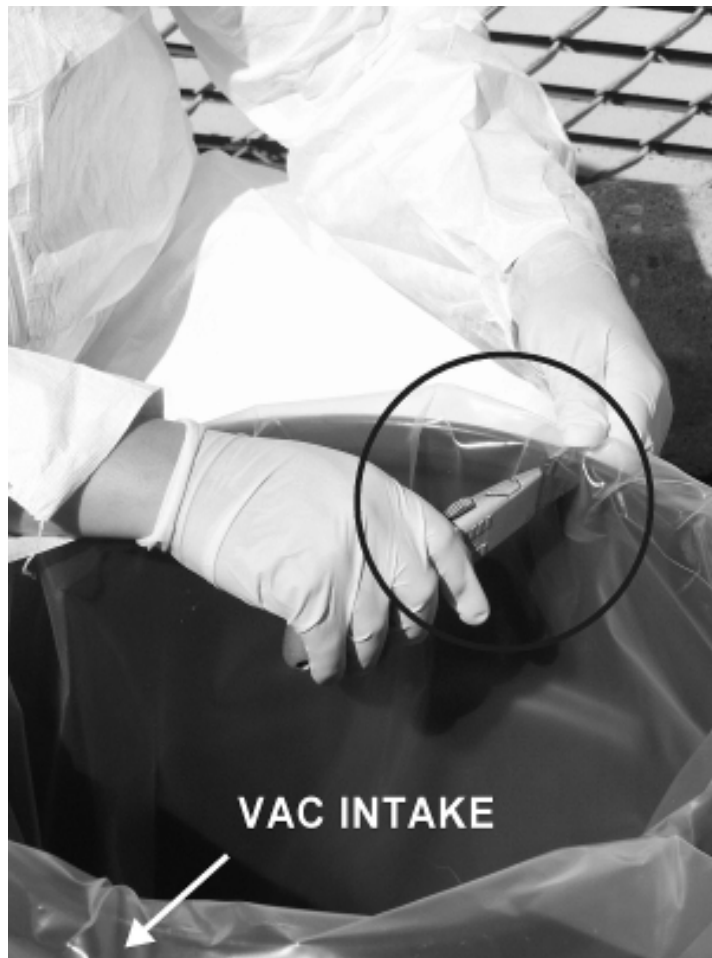

**PLEASE DO NOT DISCARD THESE INSTRUCTIONS!**

**KEEP THIS SHEET WITH THE BAG PACKAGE!**

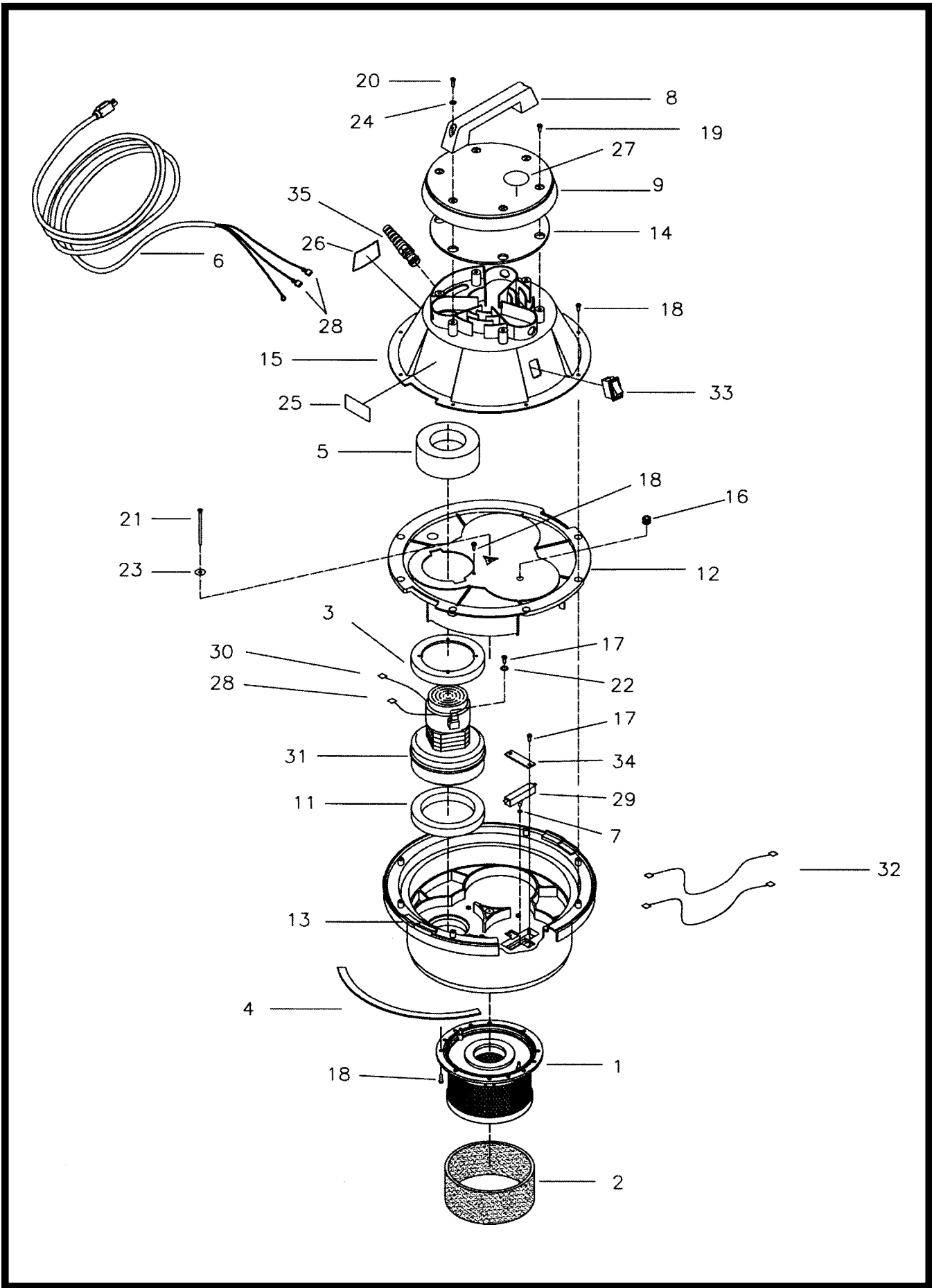



## Parts List

ITEM	PART NO.	REQ'D	DESCRIPTION
1	110029	1	FILTER-ULPA, X829 SERIES
2	110030PKG	1	PREFILTER SLEEVE, 829/839, PKG OF 6
3	290017	1	MOULDED VAC MOTOR GASKET
3A	380035	1	GASKET, 4.31 X 5.81 X .19
4	290030	1	LID GASKET DIECUT 15G 290
5	380064	1	RING, FOAM
6	381020	1	CORD-16GA-3 50FT MED GREY
6A	740600	1	CORD-EUROPEAN F3 G1.5MM 50FT B
7	390062	1	O-RING-VALVE SEAT BODY
8	460000	1	HANDLE 460 LID BLACK
9	460003	1	LID COVER 460 BLACK
10	460010	1	VACUUM HOUSING 460 BLACK
11	460019	1	GASKET 3.75 X 5.75 X .75
12	460031-A	1	MOTOR HOLDOWN SINGLE HEPA
13	460032-A	1	VAC MOTOR ADAPTER W/HEPA
14	460045	1	DOME SEAL GASKET 290
15	460070	1	COVER-MOTOR NEW STYLE SINGLE
16	700287	1	GROMMET
17	711124	3	SCR-ST-B 10 X .37 NI
18	711160	21	SCR-HI/LO #10 X 5/8 ZINC
19	711161	4	SCR-HI/LO #10 X 3/4 ZINC
20	711162	2	SCR-HI/LO #10 X 1 1/2 ZINC
21	711170	1	SCR #10 A POINT X 3.5
22	711553	1	WSR-INT LOCK #10
23	711584	1	WSR #10
24	712320	2	WSR .20 X .45 X .048 NYL
25	715058	1	DECAL-CAUTION UL HAZARDO
26	715115	1	DECAL-WARNING PV DRY
27	715501	1	DECAL-MADE IN USA
28	740014	3	TERMINAL-14-16G 1/4 FULL INS FEMALE
29	740029	1	SWITCH-SNAP SPST PB NO/NC
30	740033	1	TERMINAL-14-16 1/4 FULL INS MALE
31	740357	1	MOTOR-VAC 120V
31A	740149	1	MOTOR-VAC 240V
32	740416	2	WIRE ASSY 14G BLACK 13.00"
33	809754	1	SWITCH-ROCKER
34	829196	1	MOUNTING BRACKET 829 SWITCH
35	833237	1	STRAIN RELIEF-W/NUT
***	829123	1	LID ASY HEPA 105POLY 115
***	829240	1	LID ASY COMP HEPA 240V

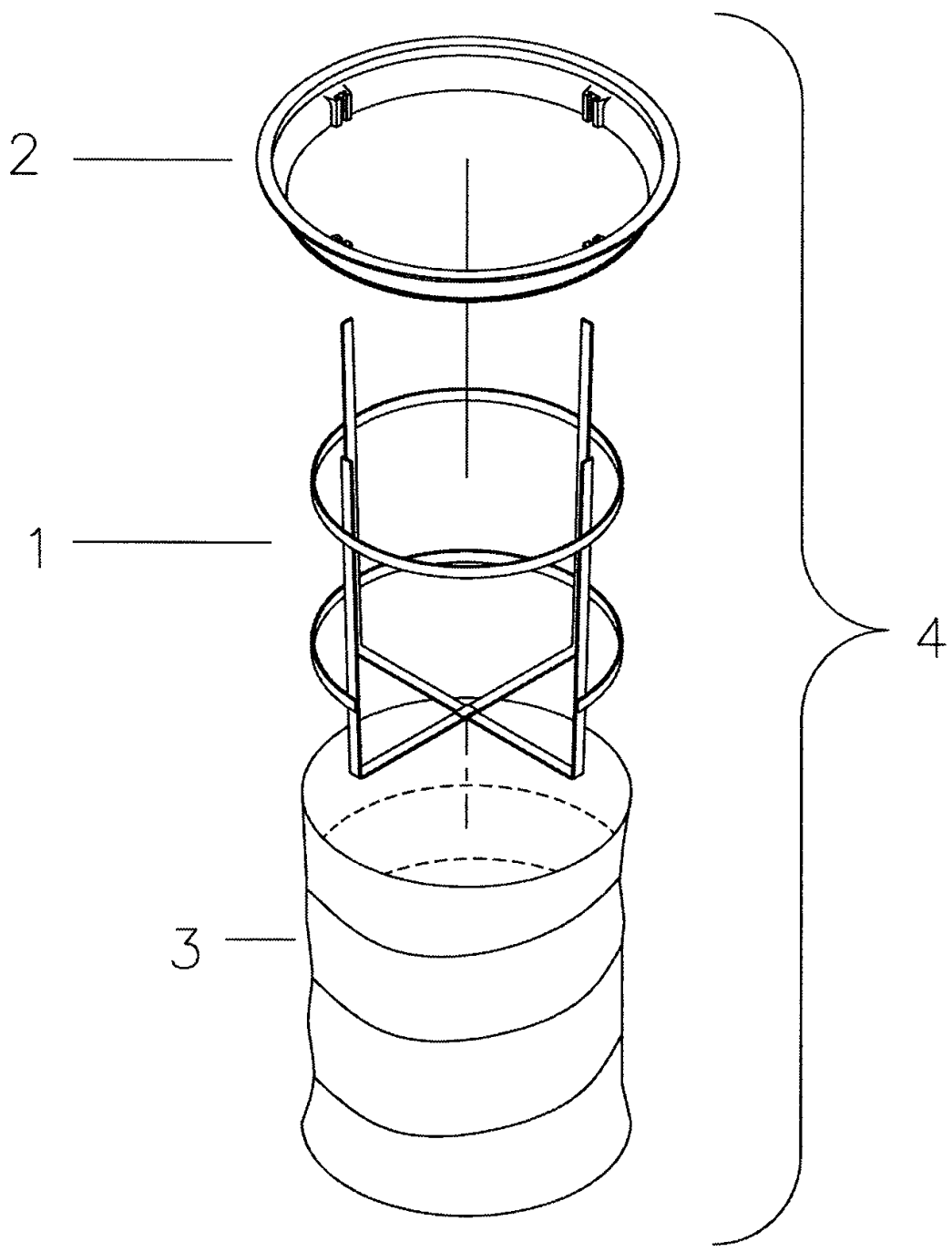

**Parts List**

Item No.	Part No.	Qty.	Description
1	750097	1	Bag Frame Weldment Asy
2	760131	1	Molded Bag Ring - Black
3	805054	1	Cloth Bag Only New Style
4	805057	1	Bag Assy. Complete w/Frame

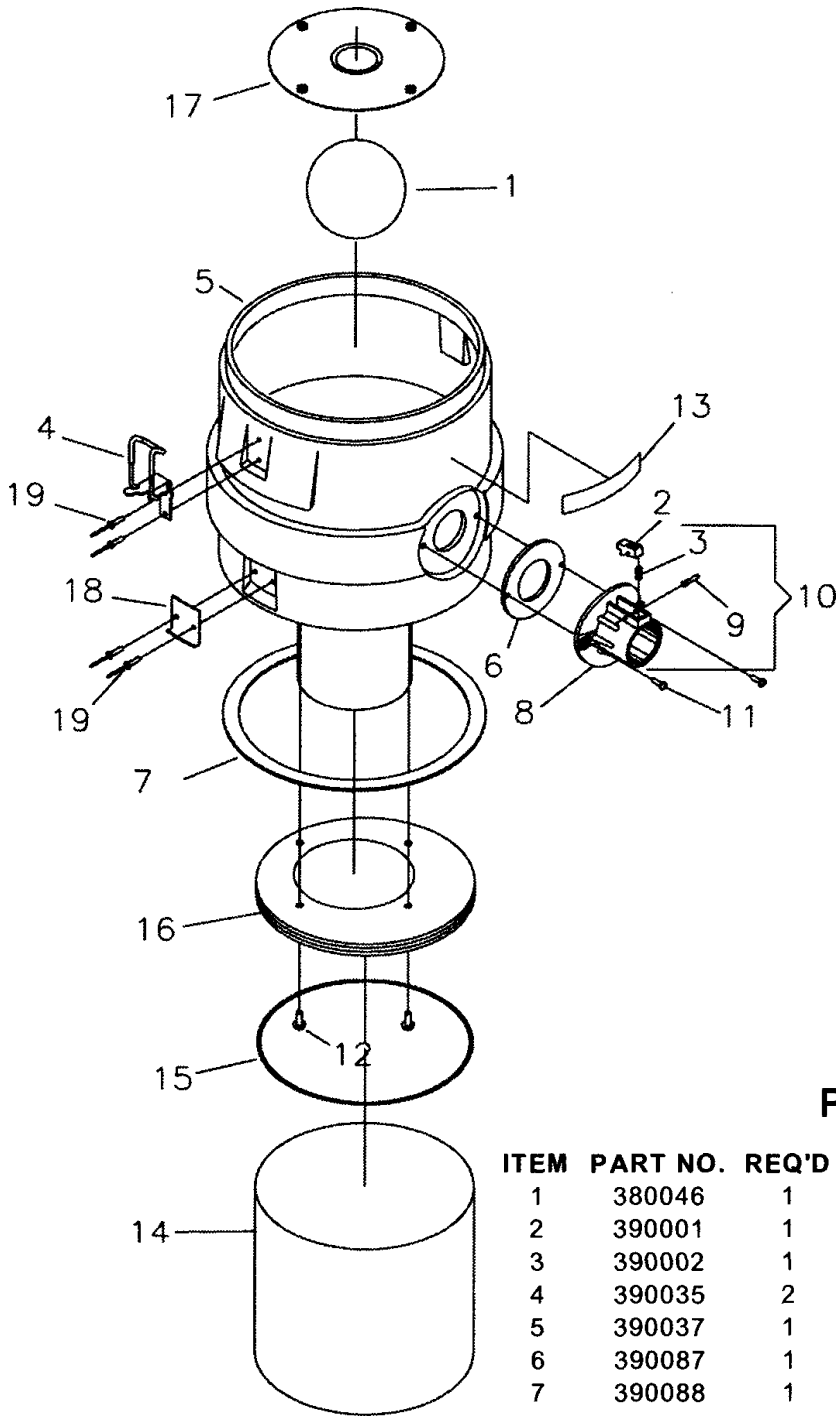

## Parts List



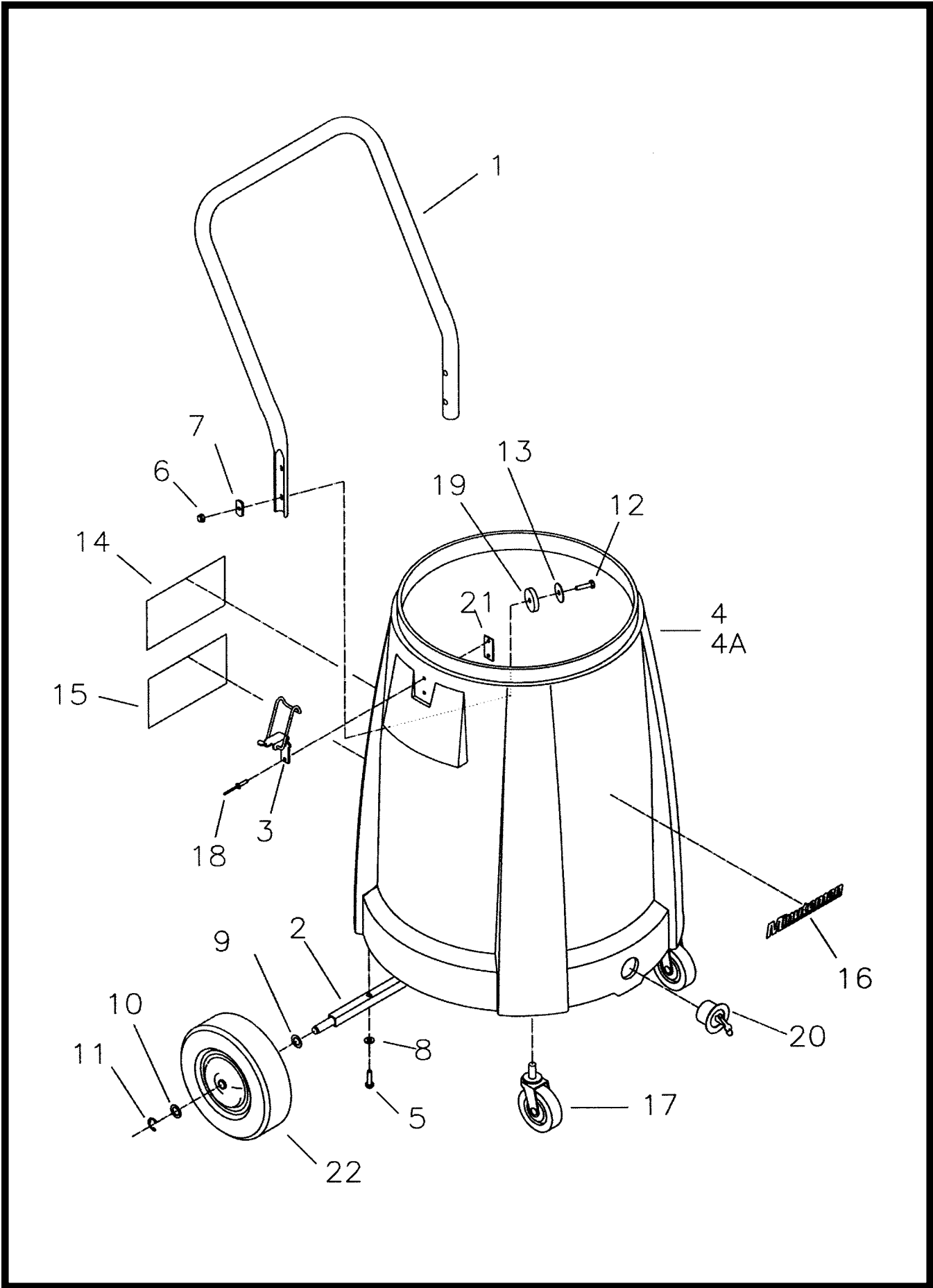

ITEM	PART NO.	REQ'D	DESCRIPTION
1	380046	1	BALL, HOLLOW RUBBER
2	390001	1	MOLDED TRIGGER
3	390002	1	SPRING-RETURN (390001)
4	390035	2	LATCH-390 SERIES COATED
5	390037	1	ADAPTER POLY 1:1 BURGUNDY
6	390087	1	GASKET DIECUT VNN
7	390088	1	GASKET PS BACK 1:1 POLY
8	390101	1	INTAKE
9	390108	1	PIN-PIVOT
10	390110	1	INTAKE ASSEMBLY ALUMINUM
11	712530	2	SCR-MC 10-24 X .62 SS
12	712565	4	SCR-MC 1/4-20 X .62 SS
13	715381	1	DECAL-MMAN .8 X 5.5 LT GRAY
14	760234	1	BAG, LINT TRAP FILTER 10 X 9 1
15	760260	1	SPRING-RETAINER BAG
16	762300	1	MOUNTING PLATE PRE FILTER
17	800422	1	LIQUID SHUTOFF PLATE
18	800423	2	LATCH PLATE ZINC PLT
19	828893	8	RIVET-BAP KTR64BX

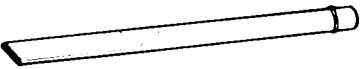

## Parts List

ITEM	PART NO.	REQ'D	DESCRIPTION
1	390031	1	HANDLE PLT 390 SERIES
2	390033	1	AXLE 390 SERIES PLATED
3	390035	2	LATCH-390 SERIES COATED
4	390041	1	TANK 15GRC NO HOLES
4A	390051	1	TANK 20GRC W/ NO HOLES
5	710182	2	SCR-MC 1/4-20 X 1.00 ZINC
6	711352	4	NUT-ACORN 1/4-20 ST N1
7	711444PLT	4	NUT-WELD 1/4-20 PLATED
8	711505	2	WSR-FLT 1/4
9	711524	2	WSR-WAVE .52 X .87 X .01
10	711594	2	WSR-FLT .56 X .88 X .03 NICKEL
11	711713	2	RET RING-E EXT .50
12	712541	4	SCR-TR HD 1/4-20 X 1.0 SS
13	712761	4	WSR-FLT .28 X 1.25 X .059 SS
14	715119	1	DECAL-DANGER 3.25 X 7
15	715120	1	DECAL-INSTRUCTIONS 3.25 X 7
16	715383	1	DECAL-MMAN 1 X 6.88 LT GRAY
17	804457	2	CASTER-3" BLACK HUB/GREY TIRE
18	828894	4	RIVET-POP BAPKTR-69
19	828980	4	GASKET
20	833316	1	DRAIN PLUG
21	833831	2	CLAMP BACK PLATE
22	900008	2	WHEEL-8.00 DIA.
***	390040	1	TANK ASY 15GRC NO INT W/DP
***	390050	1	TANK ASY 20GRC NO INT W/DP

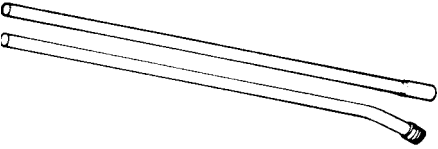
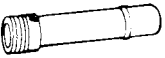
# OPTIONAL INDUSTRIAL TOOLS AND ACCESSORIES

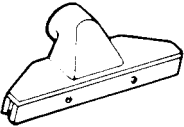
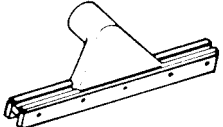
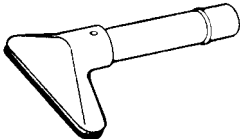
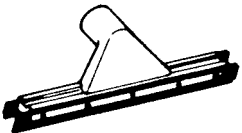
<b>A</b>		800024 3" Rd. Dust Brush Complete 800022 5" Rd Dust Brush Complete 800023 Bristle Insert 5" 800175MCH Dust Brush HSG 5" 800176MCH Dust Brush HSG 3" 800025 Bristle Insert 3"
<b>B</b>		800034 24" Crev Tool Aluminum, Complete
<b>C</b>		800015 Wand Assy. 1-1/2, Complete
<b>D</b>		800017 Set Tube, High-up 10' 800064 5' Tube Lower Section 800019 5' Section Upper
<b>E</b>		800116 Swivel, Hose End Exp. Complete
<b>F</b>		800317 Hose Assy. 1-1/2 x 10'
<b>G</b>		800032 6" Curved Pipe Tool, Complete 711006 Set Screw 800033 Bristle Insert Curved 6" 800193POL 6" Curved Pipe tool
<b>H</b>		800070 12" Gulper Tool, Complete 710356 SCR-MC 10-32 x .62 710357 SCR-MC 10-32 x .75 800187PTD Gulper Nozzle 800217 Fibre Shoe Rear 800218 Fibre Shoe Front
<b>I</b>		800108 14" Fibre Tool Complete 710530 Screw 8/32 x 1/2 Brass 800003MCH Fibre Shod 800178PTD Tool Casting
<b>J</b>		800038 6" Tool w/Handle Tube, Complete 800029 Bristle Insert Replacement
<b>K</b>		800109 14" Squeegee, Complete 710330 SCR-SC 8-32 X .62 800121 14" Retaining Strip 800178PTD Casting, Tool MCH 800239 Blade Squeegee Wide 800240 Blade Squeegee Narrow

# LIMITED WARRANTY

Minuteman International, Inc. warrants to the original purchaser/user that this product is free from defects in workmanship and materials under normal use and service for a period of three years from date of purchase. In addition, Minuteman International, Inc. will, at its option, honor labor warranty claims for the first 12 months from date of sale, provided such claims are submitted through and approved by factory authorized repair stations. Minuteman International, Inc. will, at its option, repair or replace without charge, except for transportation costs, parts that fail under normal use and service when operated and maintained in accordance with the applicable operation and instruction manuals.

This warranty does not apply to normal wear, or to items whose life is dependent on their use and care, such as belts, cords, switches, hoses, rubber parts, electrical motor components or adjustments. Parts not manufactured by Minuteman International, Inc. such as engines, batteries, battery chargers, hydraulic pumps, and tires are covered by and subject to the warranties and/or guarantees of their manufacturers. Please contact Minuteman International, Inc. for procedures in warranty claims against these manufacturers.

**Special warning to purchaser** — Use of replacement filters and/or prefilters not manufactured by Minuteman International, Inc. or its designated licensees, will void all warranties expressed or implied.

A potential health hazard exists without exact original equipment replacement.

All warranted items become the sole property of Minuteman International, Inc. or its original manufacturer, whichever the case may be.

Minuteman International, Inc. disclaims any implied warranty, including the warranty of merchantability and the warranty of fitness for a particular purpose. Minuteman International, Inc. assumes no responsibility for any special, incidental or consequential damages.

This limited warranty is applicable only in the U.S.A. and Canada, and is extended only to the original user/purchaser of this product. Customers outside the U.S.A. and Canada should contact their local distributor for export warranty policies. Minuteman International, Inc. is not responsible for costs or repairs performed by persons other than those specifically authorized by Minuteman International, Inc. This warranty does not apply to damage from transportation, alterations by unauthorized persons, misuse or abuse of the equipment, use of non-compatible chemicals, or damage to property, or loss of income due to malfunctions of the product.

If a difficulty develops with this machine, you should contact the dealer from whom it was purchased.

This warranty gives you specific legal rights, and you may have other rights which vary from state to state. Some states do not allow the exclusion or limitation of special, incidental or consequential damages, or limitations on how long an implied warranty lasts, so the above exclusions and limitations may not apply to you.

## ***Minuteman***<sup>®</sup>

*A Member of the Hako Group of Companies*

### **World Headquarters**

Minuteman International, Inc.  
111 South Rohlwing Road  
Addison, Illinois 60101

Phone 630-627-6900

Fax 630-627-1130

www.minutemanintl.com

Minuteman Canada, Inc.

2210 Drew Road  
Mississauga, Ontario  
L5S 1B1

Phone 905-673-3222

Fax 905-673-5161

987230

Rev A 11/05

Printed in U.S.A.